



Vestil Manufacturing Corp.
 2999 North Wayne Street, P.O. Box 507, Angola, IN 46703
 Telephone: (260) 665-7586 -or- Toll Free (800) 348-0868
 Fax: (260) 665-1339
www.vestil.com info@vestil.com

LPC-SERIES VERTICAL PLATE CLAMPS



Receiving Instructions

After delivery, remove the packaging from the product. Inspect the product closely to determine whether it sustained damage during transport. If damage is discovered, record a complete description of it on the bill of lading. If the product is undamaged, discard the packaging.

NOTE: The end-user is solely responsible for confirming that product design, use, and maintenance comply with laws, regulations, codes, and mandatory standards applied where the product is used.

Technical Service & Replacement Parts

For answers to questions not addressed in these instructions and to order replacement parts, labels, and accessories, call our Technical Service and Parts Department at (260) 665-7586. The department can also be contacted online at <https://www.vestil.com/page-parts-request.php>.

Electronic copies of Instruction Manuals

Additional copies of this instruction manual may be downloaded from <https://www.vestil.com/page-manuals.php>.

Table of Contents		Page
Specifications		2
Signal Words		2
Safety Instructions		3 - 4
National Standards		4
Minimum Uniform Load Weight & Uniform Capacity		4
Exploded View & Bill of Materials		5
Using the Plate Clamp		5, 6, 7, 8
Record of Satisfactory Condition		8
Load Tests		9
Inspections & Maintenance		9
Labeling Diagram		10
Limited Warranty		11

SPECIFICATIONS

Documents that provide specifications for LPC-series plate clamps are available online to anyone who visits Vestil's website. Specifications include dimensions, net weight, and capacity information. To access the appropriate specifications document, navigate to this webpage: <https://www.vestil.com/product.php?FID=561>. Click the "Specifications" tab. Scroll the page to the entry for the model ladder you purchased, and click the button in the "PDF" column that looks like a pencil inside a blue-bordered box. A PDF file will open. This file is the specifications document. Print a copy of the document and keep it with your copy of this manual. The following is an exemplar specifications document for model LPC-20.

POSITIVE LOCKING PLATE CLAMP - LPC-20

*** ANY ADDITIONS, DELETIONS, OR OMISSIONS MUST BE CORRECTED ON THIS DRAWING AS THIS DRAWING WILL BE CONSIDERED ALL INCLUSIVE ***
 ALL GRAPHICS PROVIDED ARE FOR REFERENCE ONLY. IF CERTAIN DIMENSIONS ARE CRITICAL PLEASE VERIFY THOSE DIMENSIONS WITH YOUR SALESPERSON

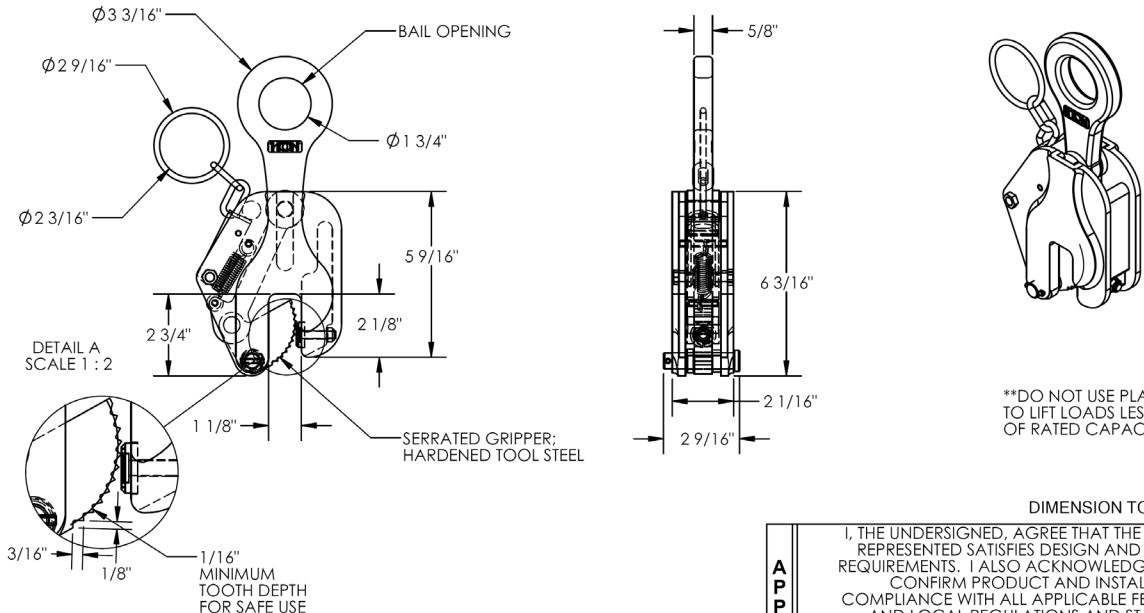

STANDARD FEATURES

- MODEL NUMBER IS LPC-20
- UNIFORM WORKING LOAD LIMIT: 2,000 LBS.
- MIN. UNIFORM PLATE WEIGHT: 400 LBS.
- MIN. PLATE THICKNESS: 0"
- MAX. PLATE THICKNESS: .80"
- THROAT DEPTH IS: 2.30"
- BAIL OPENING: Ø1 3/4"
- APPROX WEIGHT: 9 LBS.

SPECIAL FEATURES

NONE

DIMENSION TOLERANCE ± 1/4"

APPROVAL

I, THE UNDERSIGNED, AGREE THAT THE PRODUCT AS REPRESENTED SATISFIES DESIGN AND DIMENSION REQUIREMENTS. I ALSO ACKNOWLEDGE MY DUTY TO CONFIRM PRODUCT AND INSTALLATION COMPLIANCE WITH ALL APPLICABLE FEDERAL, STATE AND LOCAL REGULATIONS AND STANDARDS.

ANY MODIFIED UNITS ARE NON-RETURNABLE

[] As drawn [] As marked

Signed: _____ Date: _____

Printed Name: _____

LEAD TIME WILL START UPON RECEIPT OF SIGNED APPROVAL DRAWING

FOR INTERNAL USE ONLY PROJECT SIGN OFF		DISTRIBUTOR'S NAME: VESTIL MANUFACTURING		P.O.# X
SALES		DRAWN BY:	DATE:	W.O.# X
ENG.		REFERENCE: X	SCALE: 1:4	SALES: X
FAB.		QUOTED LEAD TIME: X	QUOTE # X	FILE NAME: 49-007-022
POWER				

SIGNAL WORDS

SIGNAL WORDS in this manual draw the reader's attention to important safety-related messages.

- ⚠ DANGER** Identifies a hazardous situation which, if not avoided, **WILL result in DEATH or SERIOUS INJURY**. Use of this signal word is limited to the most extreme situations.
- ⚠ WARNING** Identifies a hazardous situation which, if not avoided, **COULD result in DEATH or SERIOUS INJURY**.
- ⚠ CAUTION** Indicates a hazardous situation which, if not avoided, **COULD result in MINOR or MODERATE injury**.
- NOTICE** Identifies practices likely to result in product/property damage, such as operation that might damage the product.

SAFETY INSTRUCTIONS

Vestil strives to identify all foreseeable hazards associated with the use of its products. However, material handling is dangerous and no manual can address every conceivable risk. Ultimately, the most effective way to prevent injury is to apply sound judgment whenever using this device.

WARNING

Improper or careless use of this product might result in death or serious personal injuries.

- **Read and understand the entire manual before using, inspecting, or servicing the plate clamp.** DO NOT use this device until you read and understand the entire instruction manual. Read the manual to refresh your understanding of proper use and maintenance procedures. Review the instructions and safety messages included in the manuals for your crane, trolley, hoist, and any other device used in conjunction with the clamp. Use this device as instructed in this manual. You must also follow applicable provisions of [ASME B30.20 "Below-the-Hook Lifting Devices"](#) (BTH), and all laws, regulations, codes, etc. that apply to BTH devices where the clamp is used.

- **Electrocution Risk: Avoid contact with live electrical wires**

- DO NOT open the clamp while lifting or moving material. BEFORE opening the clamp be certain that the sheet material is entirely supported by the ground or other surface, and is fully stabilized e.g. can't fall over, roll, slide, or move in an uncontrolled manner. If necessary, find a second help you immobilize the material. DO NOT open the clamp while using it to lift or move sheet material.

- Inspect the plate clamp as instructed in [INSPECTIONS AND MAINTENANCE](#) on p. 9. Acquire a copy of the most recent revision of [ASME B30.20](#). Apply all applicable inspection procedures in ASME B30.20.

- Properly maintain the plate clamp according to the [maintenance procedures](#) on p. 9 of the manual. **These procedures supplement the maintenance recommendations of ASME B30.20.** If any instruction in this manual conflicts with B30.20, then you should apply the provision in B30.20. DO NOT use this lifter if it is damaged, malfunctioning, or missing parts.

- ALWAYS attach the plate clamp to a safety hook to prevent accidental/unintended detachment from the hoist. DO NOT use a hoist hook that might accidentally/unintentionally release the clamp.

- DO NOT connect the clamp to a safety hook that does not function properly or that is damaged.

- Clean and dry the sheet material before attaching the plate clamp to it. In particular, clean the material where the clamp will be attached. Debris on the surfaces of the sheet material could impair the connection between the clamp and the material.

- Make sure that the path of travel is clear of debris and obstacles BEFORE picking up the load. Make sure that no person is in the travel path.

- DO NOT lift and move a sheet of material unless it balances when suspended. Attach as many clamps as necessary to balance the load while it is suspended. Load balancing is discussed in [USING THE PLATE CLAMP](#) on p. 5-8. If a load cannot be balanced, do not use the lifter to elevate it.

- Only lift the topmost sheet of a stack. Make sure that there are no items on the sheet before lifting it.

- DO NOT attach the clamp to a side edge. ONLY attach the clamp to the top edge of a plate.

- DO NOT lift more than 1 sheet at a time.

- DO NOT lift a sheet from a horizontal position. LPC's are vertical plate clamps. They must ONLY be used to lift a plate as shown in the [PROPER VERTICAL LIFT](#) warning message of Step 3 on p. 6.

- DO NOT sit on or apply any load to the sheet material held by the clamp.

- DO NOT exceed the capacity of the clamp. Never attempt to lift material that weighs more than the capacity of the clamp. Clamp capacity is provided on the data tag which is fastened to the face of your clamp. See Data Tag in [LABELING DIAGRAM](#) on p. 7.

- DO NOT lift a load higher than necessary. See [USING THE PLATE CLAMP](#) on p. 5-8.

- DO NOT raise the load over your feet or any other part of your body.

- DO NOT lift people or carry material over people. DO NOT lift any apparatus supporting/carrying people such as a work platform. The clamp must ONLY be used to lift single sheets of material.

- DO NOT get in front of or behind a suspended load while moving it. Stand to one side of the load. Grasp the safety hook of your hoist with one hand to stabilize the material. Keep feet out from underneath the load at all times. Clothing must not become entangled in the load or the lifter.

- Keep an eye on the load at all times while it is attached to the clamp.

- DO NOT leave suspended material unattended. Move the load to the unloading location, land the load, and store the clamp before leaving it.

- Referring to American National Standard ASME BTH-1, this clamp is BTH design category B (loads and variations which are severe and not accurately defined), service class 1 (20,001 to 100,000 load cycles).

⚠ WARNING

(Continued from p. 4)

DO NOT exceed these usage parameters. Permanently remove the clamp from service before exceeding the maximum number of load cycles.

- DO NOT elevate the lifter if the hoist rope/chain is kinked. Make sure that multiple part lines are not twisted around each other before elevating the clamp and the load.
- DO NOT modify the product in any way without first obtaining written approval from Vestil. Unapproved modifications automatically void the [LIMITED WARRANTY](#) (p. 11) and might make the product unsafe to use.
- Avoid load swing by making sure the hoist rope/chain is vertical before raising the load.
- Carefully raise, lower, and move loads with the clamp. DO NOT start or stop suddenly. Sudden stops/starts might induce load swing or disrupt the connection between the clamp and the sheet.
- DO NOT drag loads with the clamp.
- DO NOT remove or deface labeling on the clamp. DO NOT use the clamp UNLESS each label is in place, undamaged, and easily readable from a reasonable distance. See [LABELING DIAGRAM](#), p. 10.
- Inspect the product as instructed in [INSPECTIONS AND MAINTENANCE](#) on p. 9.
- DO NOT elevate the lifter any higher than necessary. Keep it as close to the ground as possible.
- DO NOT use the lifter if it is tagged "Out of service" or is otherwise designated as malfunctioning.

NATIONAL STANDARDS

LPC-series products are Below-the-Hook lifting (BTH) devices. They facilitate the handling of materials in sheet form. American National Standard ASME B30.20 (the "Standard") can be purchased online at <https://blog.ansi.org/2018/10/asme-b30-20-18-changes-below-hook-lifting/>. The Standard provides inspection, testing, maintenance, and operation instructions for users of BTH devices. Acquire a copy of the Standard. Apply all provisions that apply to *Structural and Mechanical Lifting Devices*. Contact local occupational safety and health specialists to determine whether there are laws, ordinances, codes, etc. ("authorities") in addition to the Standard that apply to BTH devices in the location where the plate clamp will be used. If content in this manual conflicts with provisions in authorities or the Standard, apply the provisions from the authorities or Standard. Please contact Vestil's [TECHNICAL SERVICE](#) department to report conflicts as soon as they are discovered.

MINIMUM UNIFORM LOAD WEIGHT & UNIFORM CAPACITY

In order for the clamp mechanism to securely attach to a sheet of material, a sheet of material must weigh at least as much as the [MINIMUM UNIFORM LOAD/PLATE WEIGHT \(MUPW\)](#) of the model of your plate clamp. Do not attempt to lift a sheet if the sheet weighs less than the MUPW of your clamp. Do not attempt to lift a sheet of material that exceeds the capacity of your clamp.

MODEL	MINIMUM UNIFORM PLATE WEIGHT	UNIFORM CAPACITY
LPC-20	400 lb. (181.8 kg)	2,000 lb. (909.1kg)
LPC-40	800 lb. (363.6 kg)	4000 lb. (1,818.2kg)
LPC-60	1,200 lb. (545 kg)	6,000 lb. (2,727kg)

DIMENSIONS

Dimensions are subject to change without notice. Measure dimension A after you receive your unit and include it in the [RECORD OF SATISFACTORY CONDITION](#) on p. 8.

MODEL	A	B	C	D	E
LPC-20	7/8"	4 27/32"	2 9/16	10 13/16"	2"
LPC-40	1 3/16"	6 1/8"	3 1/8"	12 13/32"	2"
LPC-60	1 9/16"	7 5/32"	3 9/16"	14"	2"

1" = 2.54cm 2.2 lb. = 1kg

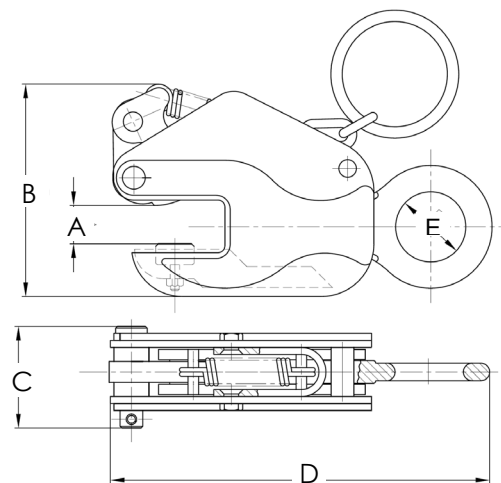

EXPLODED VIEW AND BILL OF MATERIALS

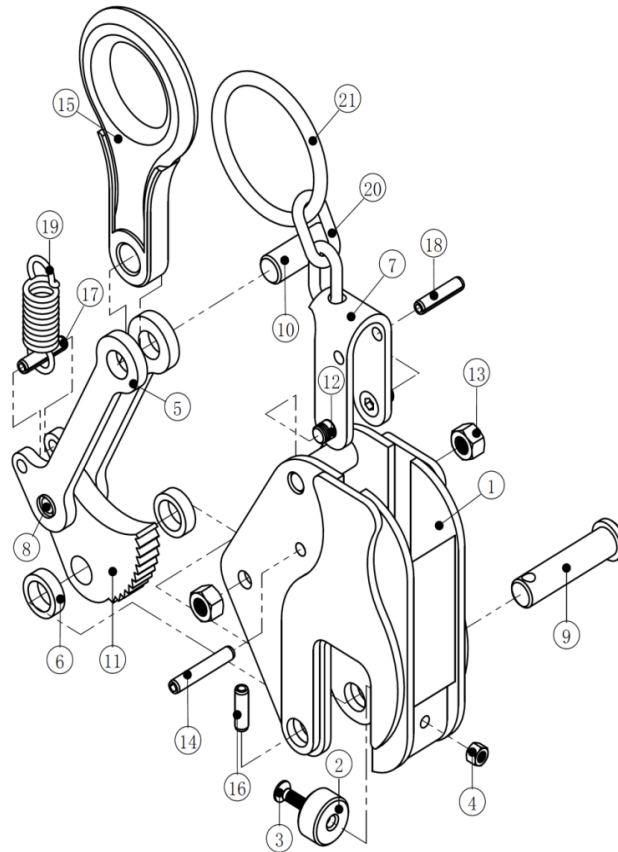

PART NO.	DESCRIPTION	QTY.	PART NO.	DESCRIPTION	QTY.
1	Cover Assembly	1	12	Gripper Pin	1
2	Pad	1	13	Lock Nut	1
3	Heavy Bolt	1	14	Spring Pin	1
4	Lock Nut	1	15	Shackle	1
5	Connecting Link	2	16	Spring Pin	1
6	Ring	2	17	Spring Pin	1
7	Lock Wheel Assembly	1	18	Spring Pin	1
8	Gripper Pin	2	19	Spring	1
9	Axis Pin	2	20	Chain Link	2
10	Link Pin	1	21	Lock Ring	1
11	Gripper/Cam	1			

USING THE PLATE CLAMP

NOTE: **The clamp is BTH design category B, service class 1.** It is not designed for use with stainless steel or aluminum sheets. Materials must have surface hardness up to 30 RC (300 HB).

This lifter is a below-the-hook lifting device, design category B (used for loads and variations which are severe and not accurately defined), service class 1 (20,001 to 100,000 load cycles). It should only be operated by qualified personnel. ASME B30.20 defines *qualified person* as "a person who, by the possession of a recognized degree in an applicable field or certificate of professional standing, or who, by extensive knowledge, training, and experience, has successfully demonstrated the ability to solve or resolve problems relating to the subject matter at hand." Qualified persons include designated persons, trainees under the direct supervision of a designated person, maintenance personnel, test personnel, and inspectors.

The Instructions provided in this manual are meant to **supplement** the recommendations of ASME B30.20. Only trained, qualified persons should use the plate clamp.

STEP 1: Perform an **EVERY LIFT INSPECTION** as described in the [INSPECTIONS & MAINTENANCE](#) section of this manual (p. 9). If the clamp is in [SATISFACTORY CONDITION](#), connect the clamp to a hoist.

STEP 2: Connect the clamp to the hoisting device. Only connect the clamp to a safety hook—hook with a latch that automatically closes—to prevent accidental detachment from the hoist.

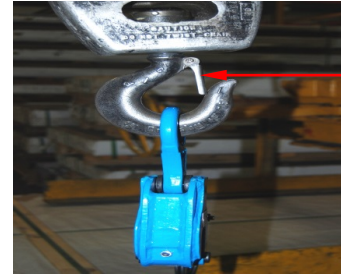

Hook with automatically closing latch

STEP 3: Unlock the clamp by rotating the lock lever away from the clamp body (see photo 1). Move the hoist above the sheet material. The sheet must balance when lifted, so position the clamp above the center of the sheet. The center of the sheet is identified with a dashed line in photo 2. **NOTE:** The sheet must weigh AT LEAST as much as the [MINIMUM UNIFORM PLATE WEIGHT](#) (MUPW) of your clamp. MUPW figures for all models are provided on p. 4. The plate thickness must be at least 25% of the maximum jaw opening. See [SPECIFICATIONS](#), dimension A on p. 2. Using the clamp to only lift sheets of the same thickness causes wear in a specific region of the gripper. The gripper has to be replaced sooner as a result.

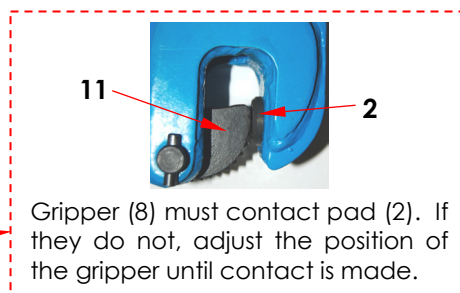
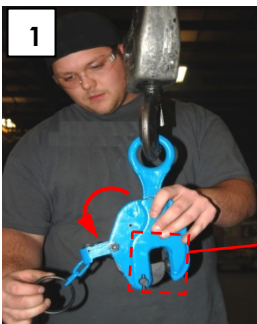

Gripper (8) must contact pad (2). If they do not, adjust the position of the gripper until contact is made.

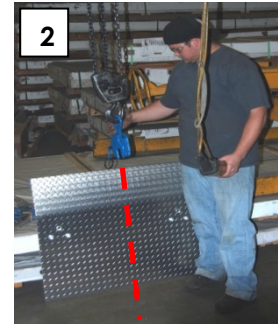

⚠ WARNING DO NOT attempt a horizontal lift. Only lift vertically. Make horizontal adjustments to the position of the clamp by moving the hoist. DO NOT push or pull the clamp so that the hoist chain/rope is not vertical. This is important because any deflection of the chain/rope from straight up-and-down will cause the load to swing when lifted. A swinging load may cause serious personal injuries.

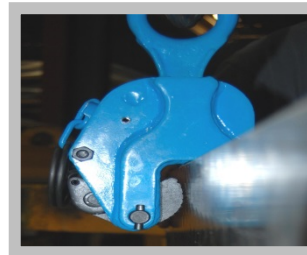

Proper Vertical Lift



Improper Horizontal Lift

STEP 4: Engage the sheet with the clamp. Press the clamp onto the top edge of the sheet. The top edge of the sheet must touch the back of the clamp mouth (photos 4a – 4c). Lock the clamp by rotating the lock lever towards the clamp body.

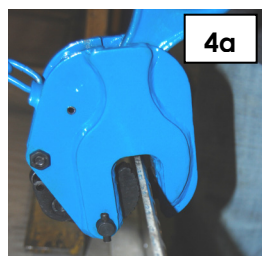

Top of sheet contacts back of the clamp mouth.

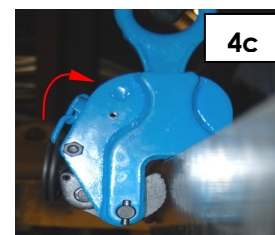
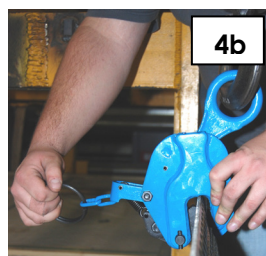

Lock the clamp

STEP 5: Confirm that the sheet balances when suspended. Raise the load **a few inches above the ground** or other supporting surface (see photo 5). The material is balanced if the top edge is substantially level. If it is not level is one side is lower than the other side). If improperly balanced, return the sheet to the ground or other supporting surface and immobilize it. Reposition the clamp to improve balance by moving the clamp slightly towards the end that hung lower during the test; then raise the object again to see if it is balanced. **DO NOT** proceed to the next step until the load is properly balanced. **DO NOT use the clamp if you cannot achieve a balanced hold; use a different lifting device to raise and move the sheet.**

- Use more than 1 clamp if the load cannot be balanced with a single plate clamp (long or flexible load). For instance, connect a chain sling to the hoist hook and attach a plate clamp to each end of the sling via safety hooks. This setup is demonstrated in the below diagram. Test the balance of the sheet material again by repeating the process of this Step (5). Do not continue to step 6 until the sheet balances.

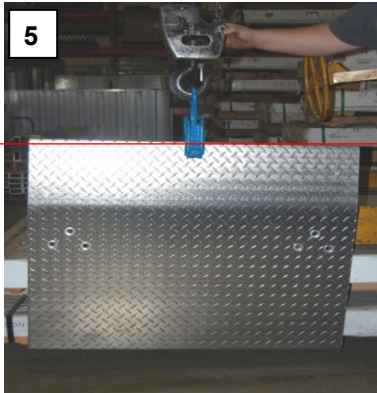

Level line
This side of the sheet material hangs lower than the other. Return the material to the ground (or other supporting surface) and reposition the clamp by moving it closer to this end.

Diagram: Use of 2 or More Clamps

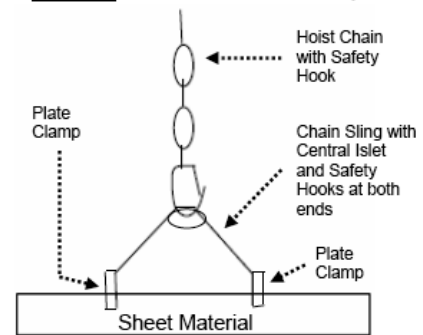

STEP 6: Lift the sheet to an ergonomically comfortable height. Steady the load by grasping the hoist hook or the bale of the clamp. Do not apply any weight to the top edge of the sheet material. Do not touch the lock lever. Avoid contact with the lock ring. Walk slowly and move the load to the work location.

LIFTING RULES

- Regularly review and apply all [SAFETY INSTRUCTIONS](#) from p. 2-3, as well as the *Operation* section of the applicable chapter of ASME B30.20.
- NEVER lift material over yourself or other persons. Inform people in the work area that you are going to use the clamp. Make sure that all persons have cleared the area before lifting and moving material.
- Stabilize suspended material by grasping the hoist hook or clamp bale while raising, lowering, or moving the material.
- Always stand at arm's length to the side of the material.** If two or more clamps are used, grasp the clamp (bale) that provides you with the most control of the sheet material. The below diagram labeled "Properly grasp the second clamp" illustrates the situation where grasping the trailing clamp provides the best control. If you cannot adequately control the sheet by yourself, ask someone to help you. The second person should grasp another clamp (bale). Make sure that your clothing, feet, and the rest of your body stay out from underneath the load. This stance allows the operator to exercise some control of the load and optimizes safety.
- The sheet must remain substantially level while it is moved. Walk slowly. Keep the load level.
 - If your hoist is moved by a motorized trolley, allow the trolley to provide all movement. **DO NOT** push or pull the clamp or the load.
 - If you use a manual trolley, grasp the clamp with one hand and carefully move the trolley. **DO NOT** push or pull the sheet. Walk slowly to keep the load level.



Diagram: Using 2 Plate Clamps

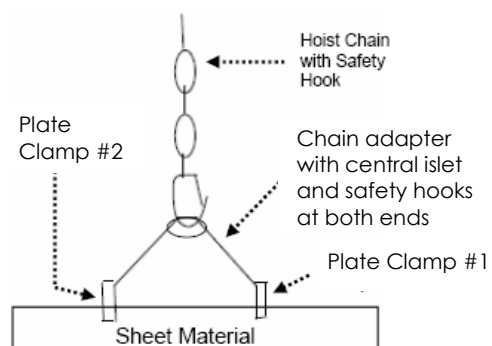

DIRECTION OF TRAVEL →

STEP 7: Make sure that the load is not swinging or rotating. Slowly lower the hoist hook until the load contacts the ground or work surface. Lower the load sufficiently to create slack in the clamp chain. **DO NOT** disconnect the clamp from the sheet until the material has been stabilized. **If you cannot control BOTH the clamp and sheet material without difficulty, ask someone to help you.**



Bale leans to the left; hoist hook supports the bale.

STEP 8: Release the load. Rotate the lock lever to the unlocked position. Pull the clamp off of the sheet; then disconnect the clamp from the hoist hook. **NOTE:** It might be necessary to wiggle the clamp to loosen the connection between the gripper and the sheet.

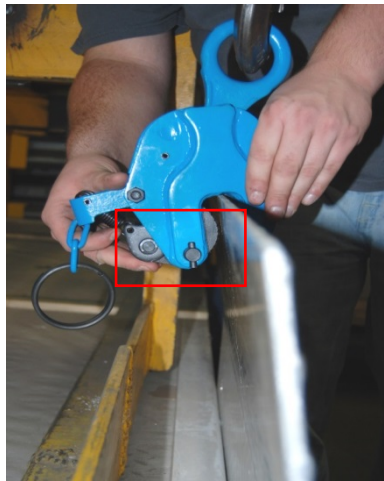

RECORD OF SATISFACTORY CONDITION (THE “RECORD”)

Record the condition of the plate clamp before putting it into regular service. Thoroughly photograph the unit. Include close range photos of all labels and tags, the bale, the gripper and pad, and the lock mechanisms. Measure the length and width of the bale opening. Measure the gripper teeth. Measure the throat opening in 3 places: 1) The mouth; 2) Where the pad is located; 3) Back/top of the throat. Record your measurements. Write a description of the overall condition of the clamp. How much force is required to lock and unlock the clamp. Lock the clamp. Try to manually move the gripper. There should be definite resistance against movement while the lock is engaged. Collect all photographs and writings in a single file. Mark the file appropriately to identify it. The file is a record of the clamp in satisfactory condition. Compare the results of all inspections to this *RECORD* to determine whether the unit is in satisfactory condition. If the clamp is not in satisfactory condition, repair it before returning it to service. Purely cosmetic changes, like damaged paint/powdercoat, do not constitute changes from satisfactory condition. However, touchup paint should be applied to all affected areas as soon as cosmetic damage occurs to prevent rusting and corrosion. If left unaddressed, rust/corrosion will degrade the condition of the clamp and could make it unsafe to use.

LOAD TESTS

After creating a [RECORD OF SATISFACTORY CONDITION](#) and before using the lifter for the first time, a qualified person should conduct a load test. The test load should be 125% of the capacity of your clamp. For example, the test load for an LPC-20 clamp is $2,000 \times 1.25 = 2,500\text{lb.}$ (1136.4kg). Elevate the test load a few inches above the ground for approximately 1 minute. Ground the load and disconnect it from the plate clamp. Perform a *Monthly Inspection* as described in [INSPECTIONS AND MAINTENANCE](#) (below). The (qualified) person performing the test must compose a written report confirming the load rating of the clamp. The load rating (capacity) should not be more than 80% of the test load. The clamp must undergo load testing whenever it is repaired. Never modify the clamp.

INSPECTIONS AND MAINTENANCE

NOTICE Regular inspections and maintenance are essential. Always inspect and maintain this product in accordance with the instructions in this manual.

Apply all relevant inspection instructions in your copy of ASME B30.20 as well as the following instructions. Inspections and maintenance should only be performed by qualified persons. Compare the results of each inspection to the [RECORD OF SATISFACTORY CONDITION](#). Do not use the clamp unless all parts are in satisfactory condition. Replace parts that are not in satisfactory condition before returning the clamp to service. Only use manufacturer-approved replacement parts to restore the unit to satisfactory condition. **DON'T GUESS! If you have any questions about the condition of your lifter, contact the [TECHNICAL SERVICE](#) department.** The phone number is provided on the cover page of this manual. *Never make temporary repairs of damaged or missing parts.*

- I. Disconnect the clamp from the hoist hook and tag it "Out of service".
- II. Perform the appropriate inspection (A or B). If a component is not in satisfactory condition, repair it or replace it as necessary to restore the unit to satisfactory condition. DO NOT modify the clamp.
 - A. **Inspection before each use** – The operator must inspect the clamp before every lift. Closely inspect the bale mechanisms. Check the bale loop and bale pin for cracks, elongation, warps, and other forms of damage. Confirm that the bale mechanism is securely pinned in place. Remove debris from the clamp surfaces. Check the gripper teeth. Teeth must be sharp, clean, & dry.
 - B. **Monthly inspections** – At least once per month a qualified person must perform the following inspections and maintenance. Written reports should be prepared for every monthly inspection including inspections following [LOAD TESTS](#).
 1. **Surfaces:** Look for forging fractures, weld fractures, significant wear, and deformations/distortions, corrosion/rusting, and metal fatigue. If rusting is purely superficial, remove it with a steel bristle brush or steel wool. Clean the affected area & apply touchup paint. If rust, rot, or thinning has weakened the material, permanently remove the clamp from service.
 2. **Throat opening:** Measure the width of the throat opening in the 3 places that were measured to generate the [RECORD](#). Enlargement of the opening indicates that the clamp has been overloaded. The clamp must be permanently removed from service.
 3. **Gripper/cam, gripper teeth, and pad:** Examine the gripper teeth. If teeth are flattened by 50% or more, replace both the gripper and the pad. If the plate clamp is used to only move sheets of a particular thickness, the gripper surface will wear in only 1 area and will have to be replaced more frequently.
 4. **Spring, lock mechanisms, and pad:** The spring should hold the gripper/cam against the pad when the clamp is unloaded. The locking spring should provide little initial pressure (of the gripper) without material in the clamp. Counter-pressure should increase as the gripper is pressed away from the pad. Lock and unlock the clamp. Confirm that the lock engages and disengages satisfactorily.
 5. **Pins and pinholes, and other fasteners:** Examine all pins and pinholes. Pins should be straight. Pinholes should be round, not ovoid. Evaluate the degree of wear of all pins and pinholes. Examine pin retaining clips and spring pins (used to secure pins in place).
 6. **Bale assembly:** Measure the length and width of the bale opening and connecting link. Make sure the measurements match the measurements in the [RECORD](#). If any cracks, distortions, elongation, or severe wear is found, permanently remove the clamp from service.
 7. **Labels:** Check all labels. Labels are shown in the [LABELING DIAGRAM](#) (below). Replace labels that are missing, damaged, or not easily readable.

LABELING DIAGRAM

Label content and location are subject to change. Your product might not be labeled exactly as shown. Compare this diagram to your [RECORD OF SATISFACTORY CONDITION](#). If differences exist between the diagram and the *RECORD*, contact [TECHNICAL SERVICE](#). Replace all labels that are damaged, missing, or not easily readable (e.g. faded). Order replacement labels by contacting the parts department online at http://www.vestilmfg.com/parts_info.htm or by calling (260) 665-7586 and asking the operator to connect you to the *PARTS / TECHNICAL SERVICE DEPARTMENT*.

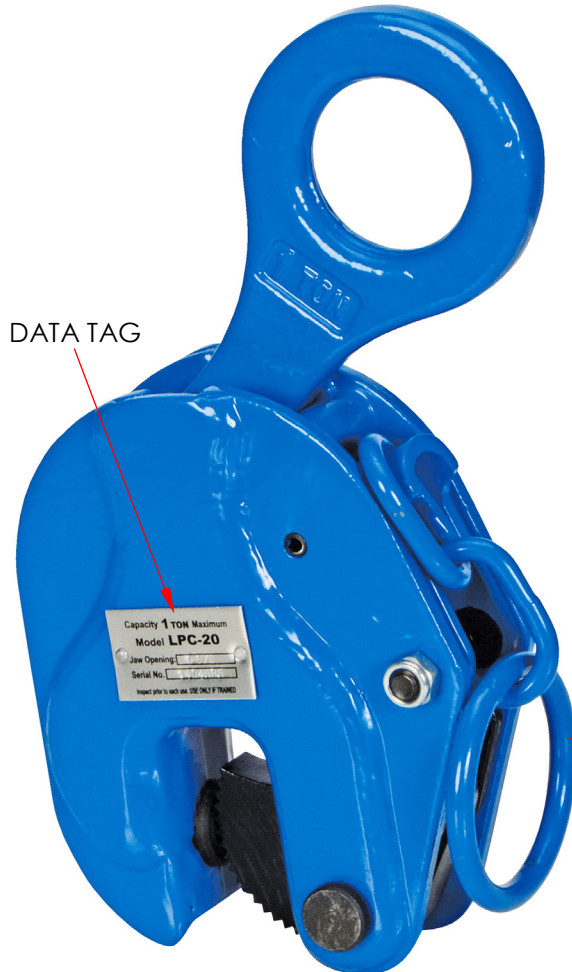

DATA TAG

Label 675 (applied to back of tag 023): Hazards

⚠ WARNING	⚠ ADVERTENCIA
<ul style="list-style-type: none"> • DO NOT exceed rated capacity • DO NOT use if damaged, malfunctioning, or missing parts • DO NOT lift people OR lift loads over people • DO NOT raise load higher than necessary • DO NOT leave a suspended load unattended • DO NOT use lifter unless you read and understand the owner's manual • DO NOT alter OR modify lifter • DO NOT remove OR obscure any label • STAY CLEAR of suspended loads • Secure load before using this device 	<ul style="list-style-type: none"> • NO exceda la capacidad tasada • NO USE is las partes estan dañadas, no funcionan correctamente o faltan partes. • NO eleve al personal o eleve cargas sobre el personal • NO eleve la carga mas alto de lo necesario • NO deje desatendida una carga que este suspendida • NO use el elevador a no ser que haya leído y entendido las instrucciones del manual del propietario • NO altere o modifique el elevador • NO quite u oscurezca ninguna etiqueta • MANTENGASE alejado de las cargas suspendidas

Tag 023 (connected to pear link via cable tie): Rated load information & BTH service class

Model No. _____	Serial No. _____
No. Modelo _____	No. Serie _____
Capacity _____ lbs.	Lifter Weight _____ lbs.
Capacidad _____ kgs.	Peso del Elevador _____ kgs.
BHT-1 Design Category: B	BHT-1 Service Category: 1
BHT-1 Categoría de Diseño B	BHT-1 Categoría de Servicio: 1
Read Owners Manual for product safety warnings Lea Manual de Propietarios para advertencias de seguridad de producto	
<small>023 rev 0511</small>	



LIMITED WARRANTY

Vestil Manufacturing Corporation ("Vestil") warrants this product to be free of defects in material and workmanship during the warranty period. Our warranty obligation is to provide a replacement for a defective, original part covered by the warranty after we receive a proper request from the Warrantee (you) for warranty service.

Who may request service?

Only a warrantee may request service. You are a warrantee if you purchased the product from Vestil or from an authorized distributor AND Vestil has been fully paid.

Definition of "original part"?

An original part is a part used to make the product as shipped to the Warrantee.

What is a "proper request"?

A request for warranty service is proper if Vestil receives: 1) a photocopy of the Customer Invoice that displays the shipping date; AND 2) a written request for warranty service including your name and phone number. Send requests by one of the following methods:

<u>US Mail</u>	<u>Fax</u>	<u>Email</u>
Vestil Manufacturing Corporation 2999 North Wayne Street, PO Box 507 Angola, IN 46703	(260) 665-1339 <u>Phone</u> (260) 665-7586	info@vestil.com Enter "Warranty service request" in the subject field.

In the written request, list the parts believed to be defective and include the address where replacements should be delivered. After Vestil receives your request for warranty service, an authorized representative will contact you to determine whether your claim is covered by the warranty. Before providing warranty service, Vestil will require you to send the entire product, or just the defective part (or parts), to its facility in Angola, IN.

What is covered under the warranty?

The warranty covers defects in the following original, dynamic parts: motors, hydraulic pumps, motor controllers, and cylinders. It also covers defects in original parts that wear under normal usage conditions ("wearing parts"), such as bearings, hoses, wheels, seals, brushes, and batteries.

How long is the warranty period?

The warranty period for original dynamic components is 30 days. For wearing parts, the warranty period is 30 days. Both warranty periods begin on the date Vestil ships the product to the Warrantee. If the product was purchased from an authorized distributor, the periods begin when the distributor ships the product. Vestil may, at its sole discretion, extend a warranty period for products shipped from authorized distributors by up to 30 days to account for shipping time.

If a defective part is covered by the warranty, what will Vestil do to correct the problem?

Vestil will provide an appropriate replacement for any covered part. An authorized representative of Vestil will contact you to discuss your claim.

What is not covered by the warranty?

The Warrantee (you) is responsible for paying labor costs and freight costs to return the product to Vestil for warranty service.

Events that automatically void this Limited Warranty.

- Misuse;
- Negligent assembly, installation, operation or repair;
- Installation/use in corrosive environments;
- Inadequate or improper maintenance;
- Damage sustained during shipping;
- Collisions or other accidents that damage the product;
- Unauthorized modifications: Do not modify the product IN ANY WAY without first receiving written authorization from Vestil.

Do any other warranties apply to the product?

Vestil Manufacturing Corp. makes no other express warranties. All implied warranties are disclaimed to the extent allowed by law. Any implied warranty not disclaimed is limited in scope to the terms of this Limited Warranty. Vestil makes no warranty or representation that this product complies with any state or local design, performance, or safety code or standard. Noncompliance with any such code or standard is not a defect in material or workmanship.